

Power solutions. Worldwide.  
Made in Germany. Since 1968.



# SYNPOL<sup>®</sup> D

Alternator Protection  
Diesel Control Unit · Power Management



For low and medium  
voltage systems

Proven life-cycle support  
for more than 30 years



## SYNPOL®D

is a product launched by stuckeGROUP in 1994, mainly sold through the global network of ABB:

- more than 5.000 units are installed on various types of vessels

## stuckeGROUP provides true 24/7 life-cycle support:

- spare parts support
- system repairs still available today
- complete replacement of all units and cables without modifications
- new design of front panel with standard stuckeGROUP logo
- download of parameter settings from old device and upload to the new one
- 5 years of warranty
- global onboard service and support

Standardized retrofit solutions available by migrating to the next generation, SYMAP® series

- more than 30.000 stuckeGROUP units are installed on various types of vessels

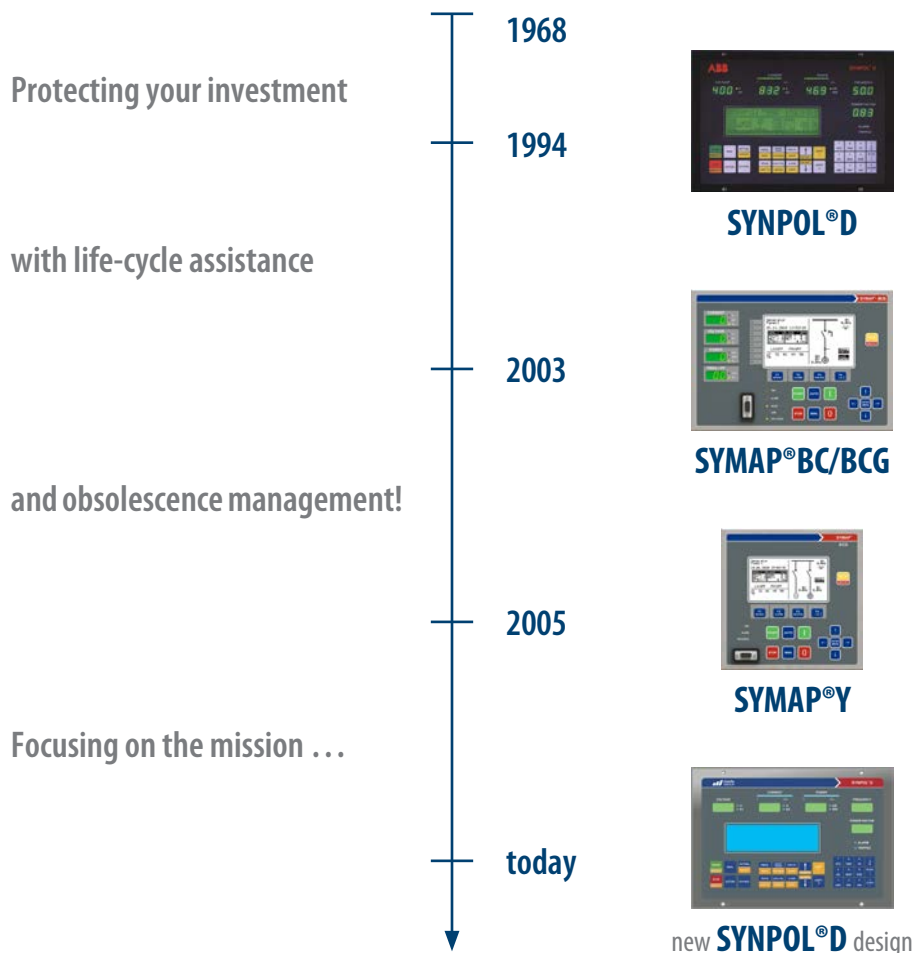

## Description

SYNPOL®D is a compact device used for the control and protection of generators and diesel engines. In addition, SYNPOL®D is equipped with a Power Management system that includes automatic connection to big consumers for controlling the entire mains system of the plant. Because of its modular structure, any central control unit does not influence the system. Since a SYNPOL®D control device is assigned to each generator panel, all generator panels are identically constructed. A two-wire bus communication (CAN bus) connects the SYNPOL®D control devices to each other. In case of the failure of one device, the others will continue operating. Each SYNPOL®D device incorporates all important functions necessary for Power Management. Thus, the system of independent and autonomous electric diesel engines has been consistently developed for switching gears, control and monitoring (modular independent systems). Optional, a PC monitor system can be connected if the CAN communication is in use.

A SYNPOL®D device is mounted on the front of the door of each generator panel. The control panel of the SYNPOL®D device contains elements for displaying all of a generator's important values. These values, permanently indicated on green seven-segment LE-displays, are:

- generator voltage
- generator current
- generator power
- generator frequency
- generator power factor

In addition to the seven-segment displays, a generator's current and power are shown by analog indication with continuous green light bands that turn red after passing the 100% mark.

Further, there is a large LC-display on the SYNPOL®D control panel, which provides the following information:

- diesel engine status display
- measuring data of the generator
- display of incoming alarms in case of exceeding value limits
- status display of the total plant when Power Management operation is in use
- display of parameters and limits for input when the programming mode is selected
- status display of internal computers

In addition, all values can be entered via a keyboard on the SYNPOL®D control panel. Some of the keys are also used for operating the diesel engine, so there is no need for a separate programming device. The key „Acknowl.“ serves for acknowledgement and resets stored alarms.

## Technical Data

Description	Specification
<b>Generator voltage</b>	
	100 V or 400-480 V
	three-phase 0.2 VA power consumption
<b>Busbar voltage</b>	
	100 V or 400-480 V
	two-phase 0.1 VA power consumption
<b>Current transformer connection</b>	
	1A three-phase
	ca. 1 VA by nominal current
<b>Frequency</b>	
	40-70 Hz
<b>Power input</b>	
	24 VDC +/- 40%
<b>Relay output</b>	
	250 V / 0.5 A AC
	250 V / 0.2 A DC
<b>Analog output</b>	
	+/- 10 V / 10 mA
	0-20 mA / 5 V
	4-20 mA / 5 V
<b>Protection</b>	
	IP 00
<b>Dimension basic unit front plate</b>	
	H=190, W=277, D=240 mm
<b>Assembly</b>	
	SYNPOL®D control device, horizontal terminal boards, any position

## The most important functions of the SYNPOL®D device

- short-circuit protection that remains effective even if the entire supply voltage of the device should fail
- selective disconnection of a faulted generator. Reconnection protection by manual resetting
- three-step overload protection by overcurrent recording
- reverse power protection
- three-step disconnection of non-essential power consuming components in case of overload, underfrequency and overcurrent
- synchronization of the alternator to the busbar
- automatic speed adaptation of the diesel engine to busbar frequency
- under- and overvoltage monitoring
- under- and overfrequency monitoring
- open circuit monitoring of the current transformer circuits
- asymmetrical current protection
- asymmetrical voltage protection
- self-monitoring of supply voltages and of program operation via watchdog function
- active power measuring, including non-sine voltages and currents and especially thyristor loads (output signal +/- 10 V/DC or +/- 20 mA/DC intended for moving coil instrument connection)
- reactive power measuring
- apparent power measuring
- current output 4-20 mA for remote control display
- permanent storage and indication of all release functions
- supply for the undervoltage coil (direct current), supporting the supply in case of short-time voltage drop
- differential protection with current-adaptive tripping characteristic and minimum differential monitoring in case generator is operating at no load
- earth-fault monitoring, including phase recognition and minimum differential monitoring in case a generator is operating at no load
- counter for following data: working hour, kWh (dual counter), KVAR, start and main breaker
- active load regulation with secondary frequency regulation, twice controlling several mains (in case tie circuit breakers are used)
- power factor in combination with voltage control in several networks
- load-free disconnection of the alternator circuit breaker
- asymmetrical load regulation with constant load setpoint
- asymmetrical power factor control with constant setpoint
- start, stop and pre-glow outputs rated for 24 V / 40 A
- galvanic separation of I/O's by opto-couplers
- galvanic separation of 24 V supply to the engine
- external connections on a separate terminal board
- individual programming for each unit by initialization routine
- actual speed measuring either by tacho generator or by pick-ups, including monitoring
- eight programmable wire fault alarm inputs that permit free determination of logic, delay and alarm text displays
- wire break monitoring of start / stop solenoids
- serial interface between several SYNPOL®D units, as well as interface for data transmission and control of external plants (RS 485, RS 422, RS 232)
- parameter setting via laptop
- menu-operated input of all limit values and parameters
- Power Management with multi-master system
- for land stations: rapid-phase-jump relay, fast voltage and frequency detector

## Protection functions

The following table shows the device type related protection functions of SYNPOL®D

ANSI No.	Protection function
2	time-relay starting or closing – time relay in a switching sequence – see relays 62 and 79
3	checking or interlocking relay
12	overspeed device
14	underspeed device
21	distance relay – operation based impedance Z – admittance Y or reactance X
24	overexcitation relay – inverse, step or definite time function – operation based on V/Hz principle
25	sync-check relay
25/A	automatic synchronizing relay
26	apparatus thermal device – general over- or undertemperature – other than 49
27	undervoltage relay
32	power relay
37	undercurrent or underpower relay
40	loss of field relay – based on field dc – current measurement or excessive reactive component of reactive current
46	phase balance / sequence I relay – incurrent phase sequence or unbalance current relay
46N	negative sequence overcurrent
47	wrong rotating sequence
50	instantaneous overcurrent relay or rate-of-rise relay
50BF	breaker tripped failure
51	time overcurrent relay
51G/N	ground overcurrent
51/27R	voltage restrained time overcurrent relay – time overcurrent relay with pick-up adjusted by undervoltage function
55	power factor relay – operates if pf slips outside operating area
59	overvoltage relay
59N	ground overvoltage relay
60FL	voltage transformer failure
67	directional overcurrent relay
81	frequency relay
86	lock out relay
87	differential relay – normally high impedance type
90	regulating device – voltage regulator
94	tripping or trip-free

## Communication

SYNPOL®D offers via the RS422/RS485 communication port the Modbus protocol in accordance with „Gould Modbus protocol“ Reference guide PI-MBUS-300 Rev. B.

The protocol controls the query and response cycle which takes place between master and slave devices.

The protocol provides for one master and up to 247 slaves on a common line. SYNPOL®D operates as slave within this network and covers the function 1,2,3,6 & 8 of the Modbus protocol.



Basic unit equipped with cable X

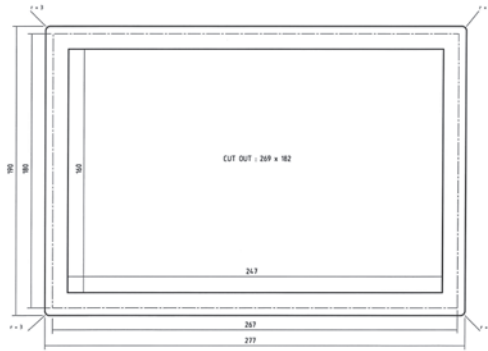

Cutout

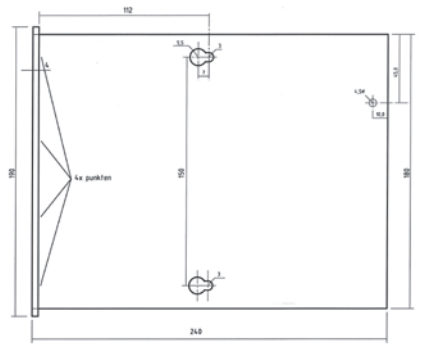

## Terminal boards

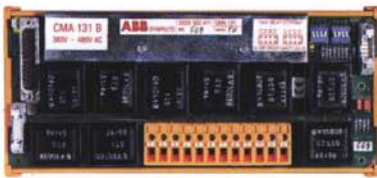

**CMA 131 generator connection**

70 x 245 x 109 mm\*

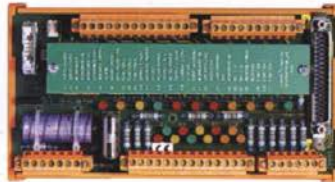

**CMA 132 generator relay card**

75 x 205 x 109 mm\*



**CMA 136 serial interface**

60 x 105 x 109 mm\*

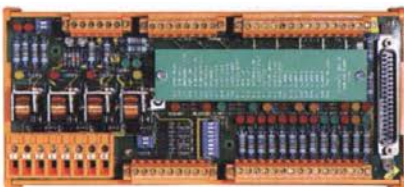

**CMA 135 diesel start, stop, control and monitoring**

75 x 240 x 109 mm\*

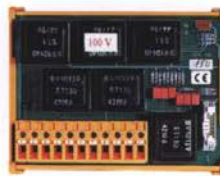

**CMA 133 differential protection and earth-fault monitoring**

70 x 145 x 109 mm\*

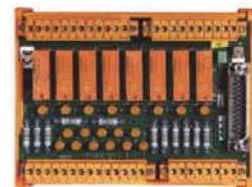

**CMA 137 additional board**

75 x 205 x 109 mm\*

\* Dimensions: height x width x depth

Terminal board CMA 131  
Terminal board CMA 132  
Terminal board CMA 133  
Terminal board CMA 134  
Terminal board CMA 135  
Terminal board CMA 136  
Terminal board CMA 137  
Terminal board CMA 138

generator connection with cable A, H  
generator relay with cable B  
differential protection and earth-fault monitoring with cable G  
resistor  
diesel start, stop, control and monitoring with cable D  
communication control with cable C  
additional functions with cable E  
special types of control

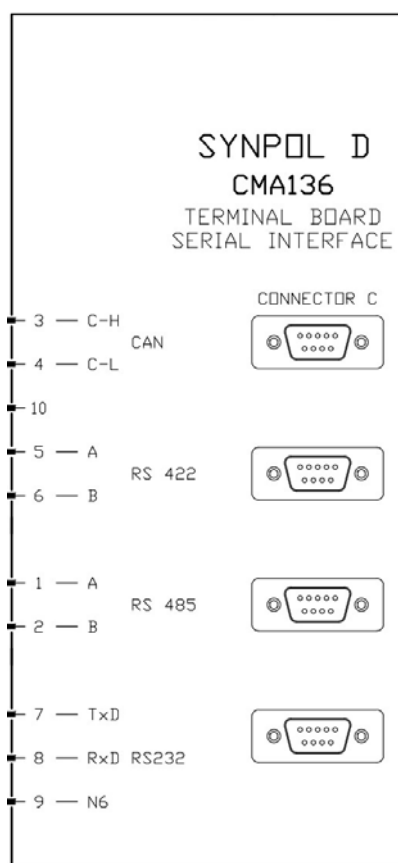
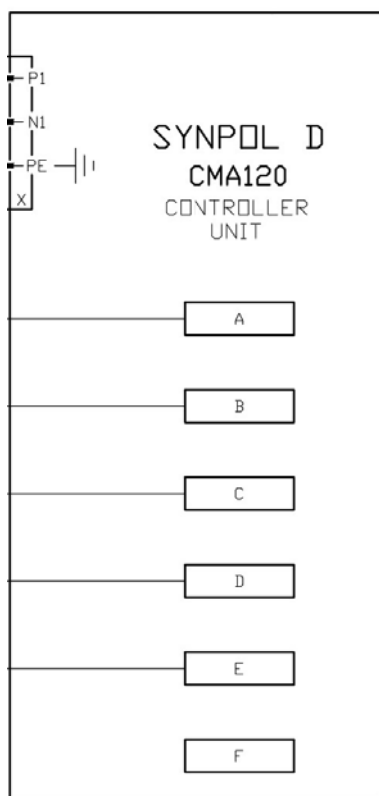
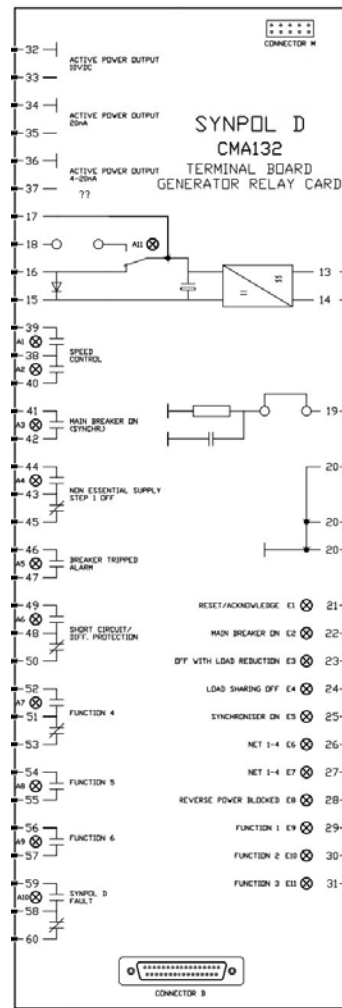
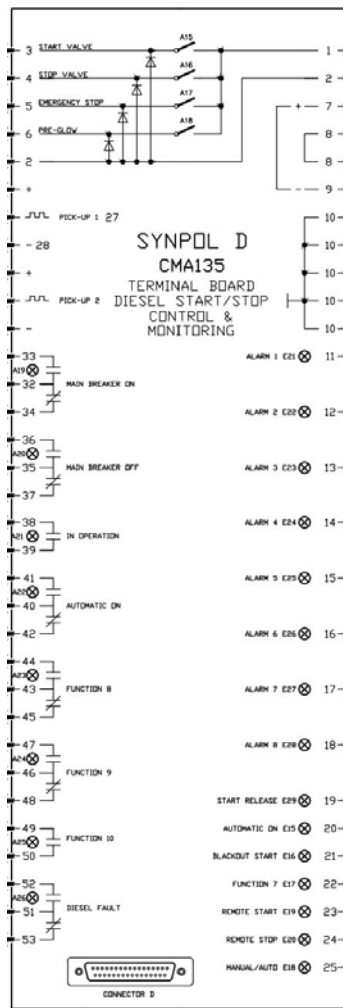
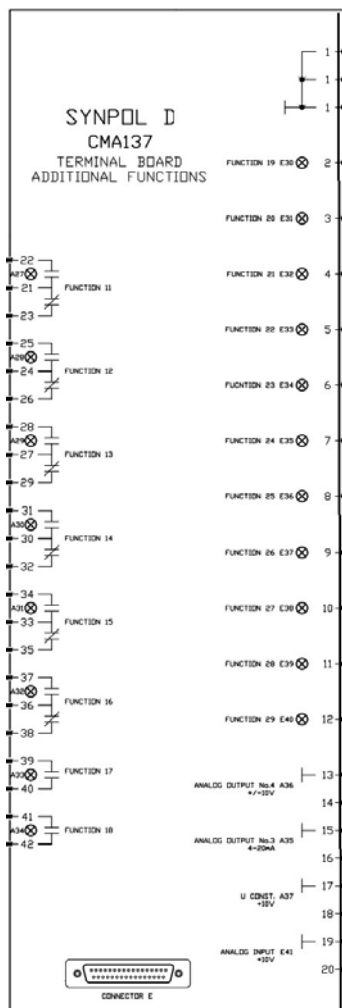

**Power solutions. Worldwide.**  
**Made in Germany. Since 1968.**

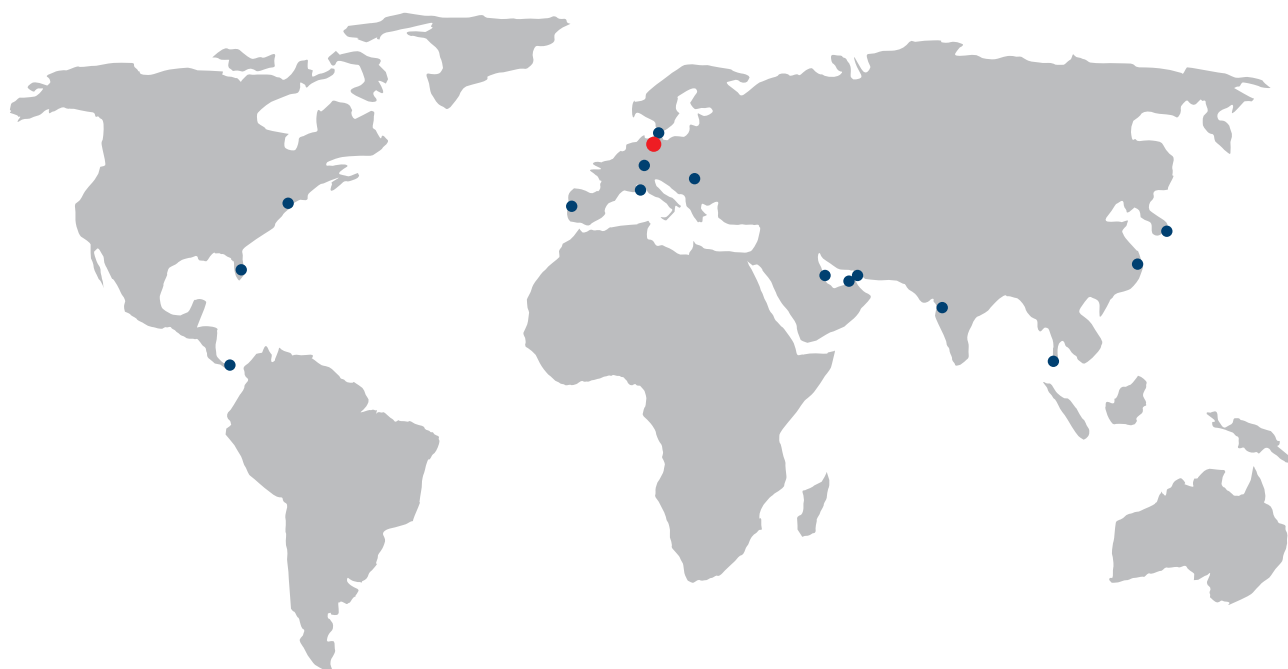

Stucke Elektronik GmbH · Head Office of **stucke**GROUP  
Merkurring 26 · 22143 Hamburg · Germany  
+49 40 227468-0 · [mail@stuckegroup.de](mailto:mail@stuckegroup.de)  
[www.stuckeGROUP.com](http://www.stuckeGROUP.com)

2026-04

